

ЛЕКТОР

Контроллер

**По вопросам продаж и поддержки обращайтесь:
сайт: www.itrpumps.nt-rt.ru || эл. почта: ixc@nt-rt.ru**

Архангельск (8182)63-90-72
Астана +7(7172)727-132
Белгород (4722)40-23-64
Брянск (4832)59-03-52
Владивосток (423)249-28-31
Волгоград (844)278-03-48
Вологда (8172)26-41-59
Воронеж (473)204-51-73
Екатеринбург (343)384-55-89
Иваново (4932)77-34-06
Ижевск (3412)26-03-58
Казань (843)206-01-48
Калининград (4012)72-03-81
Калуга (4842)92-23-67
Кемерово (3842)65-04-62
Киров (8332)68-02-04

Краснодар (861)203-40-90
Красноярск (391)204-63-61
Курск (4712)77-13-04
Липецк (4742)52-20-81
Магнитогорск (3519)55-03-13
Москва (495)268-04-70
Мурманск (8152)59-64-93
Набережные Челны (8552)20-53-41
Нижний Новгород (831)429-08-12
Новокузнецк (3843)20-46-81
Новосибирск (383)227-86-73
Орел (4862)44-53-42
Оренбург (3532)37-68-04
Пенза (8412)22-31-16
Пермь (342)205-81-47
Ростов-на-Дону (863)308-18-15

Рязань (4912)46-61-64
Самара (846)206-03-16
Санкт-Петербург (812)309-46-40
Саратов (845)249-38-78
Смоленск (4812)29-41-54
Сочи (862)225-72-31
Ставрополь (8652)20-65-13
Тверь (4822)63-31-35
Томск (3822)98-41-53
Тула (4872)74-02-29
Тюмень (3452)66-21-18
Ульяновск (8422)24-23-59
Уфа (347)229-48-12
Челябинск (351)202-03-61
Череповец (8202)49-02-64
Ярославль (4852)69-52-93

INDEX

1.- GENERAL DESCRIPTION	
1.1 General description	04
1.2 Description of front part	04
1.3 Description of display	04
2.- CARRIAGE AND MAINTENANCE	05
3.- TECHNICAL FEATURES	05
4.-FUNCTIONEMENT	
4.1 Special configuration menu	06
4.2 Gauging	07
- Gauging the conductivity probe	07
- Gauging of the PH / ORP(RX) probe	08
- Gauging of flowmeter	09
4.3 Alarms	
- Conductivity alarms	10
- PH / ORP (RX) alarms	11
5.- INSTALLATION	13
6.- MAINTENANCE	14

1.- GENERAL DESCRIPTION

1.1 GENERAL DESCRIPTION

LECTOR

Constant values display of:

- **INSTANT FLOW** (m^3 / h - GPM)
- **CONDUCTIVITY**
- **PH / ORP(RX)**

Depending on how electrodes and flowmeter are connected.

A max/min alarm can be fixed for a conductivity/PH parameter or for "0" flow.

Provided by 220/24V AC transformer - plug

1.2.- DESCRIPTION OF FRONT PART

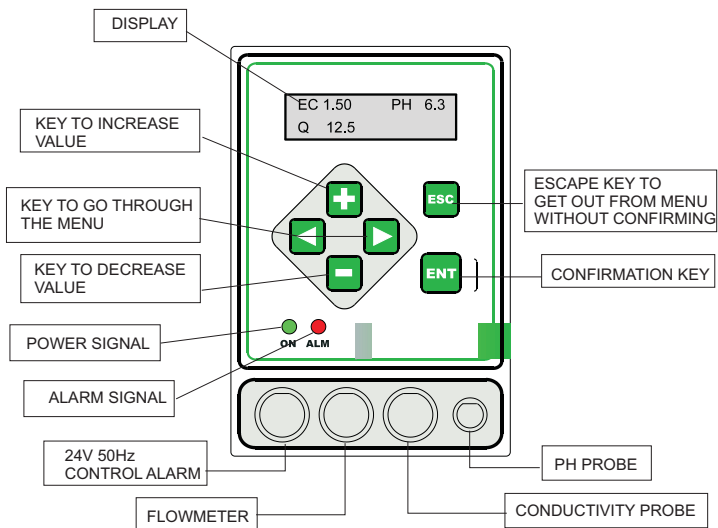

1.3.- DESCRIPTION OF DISPLAY

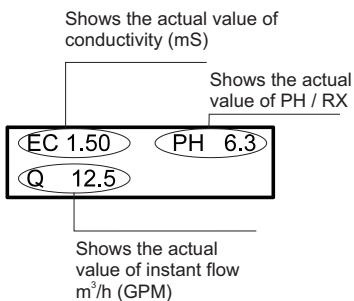

2.- CARRIAGE AND MAINTENANCE



The original packing is prepared so that carriage and storing of the product do not cause any damage to the product, as long as this is done far from heat sources and in dry, ventilated spaces.

Inside packing we include:

Lector

Handbook

Output alarm cable

3.- TECHNICAL FEATURES



Power supply: 230 V AC (+/- 20%)

Max consumption: 0,3 A

Working temperature: 0 - 45 °C

Don't leave outdoors unprotected and keep away from the sun

DIMENSIONS

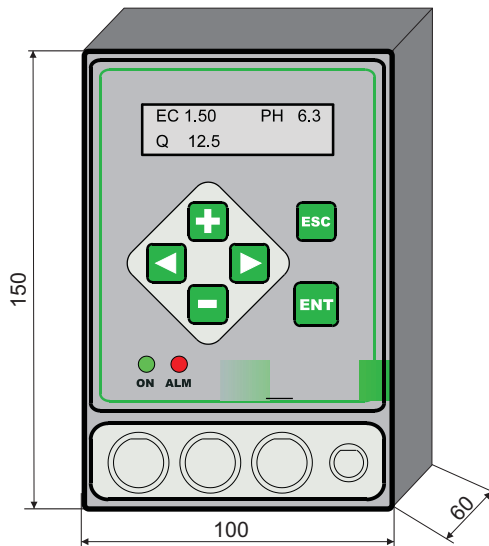

4.- FUNCTIONEMENT



4.1 - SPECIAL CONFIGURATION MENU

To reach this menu you must push both keys ESC and ENT for three seconds.

To run forward you will use the arrows (forward without validation) and ENTER (forward with validation). To modify values you will use keys +/-.

EC: 1.40 mS

Value of the conductivity buffer supplied by ITC. If another buffer is to be used, the value of the new buffer will have to be introduced.

Q UNIT: LITERS

Visualization of flow in l/hr (m³/hr) or in gallons/minute (GPM).

DIAM UNIT: MM

Visualization of diameter in MM or in inches.

FLOW K: 34.7

Amount of pulses per m/sec given by the flowmeter.

4.2 - GAUGING



GAUGING THE CONDUCTIVITY PROBE

PUSH  WILL APPEAR

EC N.NN	PH N.N
Q N.N	A NN%

 EC N.NN
in intermittent

PUSH  WILL APPEAR

EC	N.NN --
ALM	CAL

 N.NN
in intermittent

PUSH 
 WILL APPEAR

EC	N.NN --
ALM	CAL

 CAL
in intermittent

PUSH  WILL APPEAR

EC	N.NN
0.00	1.40

 0.00
in intermittent

Unplug the conductivity probe and wait for the reading to become stabilized

PUSH  WILL APPEAR

EC	N.NN
0.00	1.40

 1.40
in intermittent

Put the conductivity probe in the buffer liquid 1.4mS, wait for the N.NN to be stabilized

PUSH  WILL APPEAR

EC N.NN	PH N.N
Q N.N	A NN%

 PROBES ARE
GAUGED

GAUGING OF THE PH / ORP (RX) PROBE



PUSH  WILL APPEAR

EC N.NN	PH N.N
Q N.N	A NN%

 PH N.N
in intermittent

PUSH  WILL APPEAR

PH	N.NN --
ALM	CAL

 N.NN
in intermittent

PUSH  WILL APPEAR

PH	N.NN --
ALM	CAL

 CAL
in intermittent

Analogous sonde RX

SONDE PH:

RX	N.NN --
0	470

PUSH  WILL APPEAR

PH	N.N
7.0	4.0

 7.0
in intermittent

Put the pH probe in the pH 7 buffer and wait for the reading (N.NN) to be stabilized (1 min.approx.)

PUSH  WILL APPEAR

Ph	N.N
7.0	4.0

 4.0
in intermittent

Put the PH probe in the buffer liquid PH4, wait for the (N.NN) to be stabilized

PUSH  WILL APPEAR

EC N.NN	PH N.N
Q N.N	A NN%

 PROBES ARE GAUGED

SONDE ORP(RX):

In order to gauge "0" point it is necessary to short-circuit the two poles of the female conector BNC and then press 

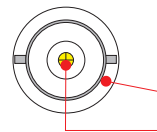

In order to gauge the ponit "470mV" it is necessary to put the probe in the buffer of 470mV and wait for the reading (N.NN) to be stabilized (1 min. aprox.) and press 

GAUGING OF FLOWMETER



PUSH  WILL APPEAR

EC N.NN	PH N.N
Q N.N	A NN%

 Q N.N
in intermittent

PUSH  WILL APPEAR

Q	N.NN% --
ALM	CAL

 N.NN%
in intermittent

PUSH  WILL APPEAR



Q	N.NN% --
ALM	CAL

 CAL
in intermittent

PUSH  WILL APPEAR

Q	NNN L/H
K 34.7	Di NN mm



 NNN
in intermittent

PUSH 
  To set the sum of the flows of the different injection modules, keeping in mind their regulation, and excluding the acid one.

PUSH  WILL APPEAR

Q	NNN L/H
K 34.7	Di NN mm

 NN
in intermittent

PUSH 
  To set the inner diameter in mm of the pipe one which the flowmeter is located.

PUSH  WILL APPEAR

EC N.NN	PH N.N
Q N.N	A NN%

 THE FLOWMETER
IS GAUGED

4.3 - ALARMS





CONDUCTIVITY ALARM

- PUSH  WILL APPEAR

EC N.NN	PH N.N
Q N.N	

 EC N.NN
in intermittent
- PUSH  WILL APPEAR

EC	N.NN
ALM	CAL



 N.NN
in intermittent
- PUSH 
  To increase or decrease the setpoint EC
- PUSH  To set the new setpoint
- WILL APPEAR

EC 2.50	PH 6.3
Q 7.8	
- PUSH  WILL APPEAR

EC N.NN	PH N.N
Q N.N	

 EC N.NN
in intermittent
- PUSH  WILL APPEAR



EC	N.NN
ALM	CAL

 N.NN
in intermittent
- PUSH 
  WILL APPEAR



EC	N.NN
ALM	CAL

 ALM
in intermittent
- PUSH  WILL APPEAR

EC > 0.0	T--
< 0.0	T--

 0.0
in intermittent
- PRESIONAR 
  To increase or decrease the maximum allowed differential
- PRESIONAR  APARECERA

EC > 0.0	T 0.0
< 0.0	T--



 0.0
in intermittent
- PRESIONAR 
  To increase or decrease the time allowed with the Differential T = - no alarm



PUSH  WILL APPEAR

EC	> N.N	T NN
	< 0.0	T --



 0.0
in intermittent



PUSH 
 To increase or decrease minimum allowed differential

PUSH  WILL APPEAR

EC	>N.N	T N.N
	<N.N	T --

 --
in intermittent

PUSH 
 To increase or decrease the time allowed with the differential
T= -- no alarm

PUSH   To validate and go back to original screen

  To go back to main screen without validation

ALARMA DE PH / RX

PUSH 
 WILL APPEAR



EC	N.NN	PH N.N
	N.N	

 PH N.NN
in intermittent

PUSH  WILL APPEAR

PH	N.NN	
ALM		CAL

 N.NN
in intermittent

PUSH 
 To increase or decrease the set-point value of PH

PUSH  To set the new set-point value

WILL APPEAR

EC	N.NN	PH N.N
Q	N.N	

PUSH 
 WILL APPEAR

EC	N.NN	PH N.N
Q	N.N	

 EC N.NN
in intermittent



PUSH  WILL APPEAR

PH	N.NN	
ALM	CAL	

 N.NN
in intermittent

PUSH  WILL APPEAR



PH	N.NN	
ALM	CAL	

 ALM
in intermittent

PUSH  WILL APPEAR

PH	>0.0	T --
	<0.0	T --



 0.0
in intermittent

PUSH 
 To increase or decrease maximum allowed differential

PUSH  WILL APPEAR

PH	>N.N	T --
	<0.0	T --



 0.0
in intermittent

PUSH 
 To increase or decrease the time allowed with the differential
T = -- no alarm

PUSH  WILL APPEAR

PH	>N.N	T NN
	<0.0	T --



 0.0
in intermittent



PUSH 
 To increase or decrease minimum allowed differential

PUSH  WILL APPEAR

PH	>N.N	T NN
	<0.0	T --

 --
in intermittent

PUSH 
 To increase or decrease the time allowed with the differential
T = -- no alarm

PUSH   To validate and go back to initial screen

  To go back to main screen without validating



5.- INSTALLATION

Relays 1 and 2 will be assembled if an electric device is to be switched ON/OFF when an alarm is activated

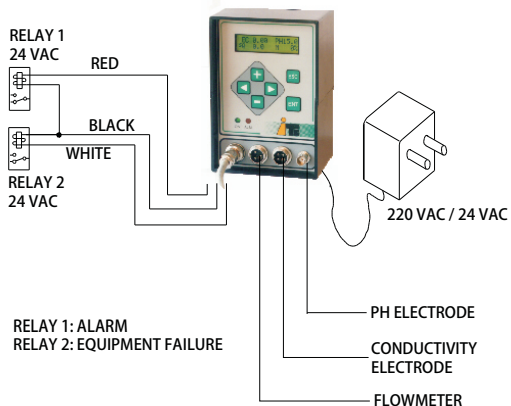

The maximum distance where we can set up the controller is the one allowed by the cable length of the different electrodes of **CONDUCTIVITY**, **pH** or **FLOWMETER (5 m / 15 ft)**.

6.- MAINTENANCE



- It is important to BUFFER the CONDUCTIVITY and pH probes regularly in order to verify their right working. To this end it is advised to use the buffers and to follow the GAUGING instructions.
- For the maintenance of the injection pump, follow the instructions therein contained.
- Never keep the pH probe dry (whether inside or outside the pipe) as it becomes very quickly polluted and it can be damaged.

**По вопросам продаж и поддержки обращайтесь:
сайт: www.itpumps.nt-rt.ru || эл. почта: ixc@nt-rt.ru**

Архангельск (8182)63-90-72
Астана +7(7172)727-132
Белгород (4722)40-23-64
Брянск (4832)59-03-52
Владивосток (423)249-28-31
Волгоград (844)278-03-48
Вологда (8172)26-41-59
Воронеж (473)204-51-73
Екатеринбург (343)384-55-89
Иваново (4932)77-34-06
Ижевск (3412)26-03-58
Казань (843)206-01-48
Калининград (4012)72-03-81
Калуга (4842)92-23-67
Кемерово (3842)65-04-62
Киров (8332)68-02-04

Краснодар (861)203-40-90
Красноярск (391)204-63-61
Курск (4712)77-13-04
Липецк (4742)52-20-81
Магнитогорск (3519)55-03-13
Москва (495)268-04-70
Мурманск (8152)59-64-93
Набережные Челны (8552)20-53-41
Нижегород (831)429-08-12
Новокузнецк (3843)20-46-81
Новосибирск (383)227-86-73
Орел (4862)44-53-42
Оренбург (3532)37-68-04
Пенза (8412)22-31-16
Пермь (342)205-81-47
Ростов-на-Дону (863)308-18-15

Рязань (4912)46-61-64
Самара (846)206-03-16
Санкт-Петербург (812)309-46-40
Саратов (845)249-38-78
Смоленск (4812)29-41-54
Сочи (862)225-72-31
Ставрополь (8652)20-65-13
Тверь (4822)63-31-35
Томск (3822)98-41-53
Тула (4872)74-02-29
Тюмень (3452)66-21-18
Ульяновск (8422)24-23-59
Уфа (347)229-48-12
Челябинск (351)202-03-61
Череповец (8202)49-02-64
Ярославль (4852)69-52-93
